

S10 Pro Datasheet

Product Overview

The Domin S10 Pro is a single stage DDV which combines high flow, excellent dynamics, strong chip shear, and low power consumption.

The S10 Pro has been designed to sustain high bandwidth operation at exceptional flows without significant limitation of operating pressures or duty cycles.

Where DDVs have been employed to control high flows there is a clear trade with packaging size and weight. The S10 Pro valve is packaged to be lower weight and more compact than the best of EHSVs.

Key Features

- Onboard electronics with spool position feedback
- Rated flow of up to 250 lpm (at 70 Bar ΔP)
- Based on the NG10 port pattern
- Bandwidth > 150 Hz (-3 dB, up to $\pm 25\%$ FS)
- Chip shear capability of > 700 N
- Valve mass of 4.2 kg

Versatile by Design

The S10 Pro is designed to be customised. Standard modifications include:

- Rated flow rates of up to 250 lpm
- Multiple voltage or current control options
- Various seal materials available
- Non-standard configurations available

Contents

Technical Data	2
Performance Graphs	3
Electronics Data	6
Electronic Interface Diagrams	9
Standards Reference	9
Unit Dimensions	10
Mounting Dimensions	11

Contact Us

If you have any questions about using the S10 Pro, or if you need a non-standard configuration, we would be happy to hear from you.

Contact us using the details below and one of our team will be there to assist you.



sales@domin.co



<https://domin.co/>



33 Colston Avenue, Bristol, BS1 4UA



+1 786 396 0835 (US)
+44 (0)333 090 5140 (UK)





Technical Data

General Data				
Design	Direct Drive servo valve			
Actuation	Rotary-Linear			
Size	NG10			
Mounting Interface	ISO 4401-05			
Ambient Temperature	°C (°F)	-20 to +60 (-4 to +140)		
Mass	kg (lb)	4.2 (9.3)		
Vibration Resistance	g	30, 3 axes		
Shock Resistance	g	50		
Hydraulic Data				
Max. Operating Pressure (P, A, B, T)	Bar (psi)	350 (5000) P, A, B, 250 (3600) T		
Fluid	Hydraulic Oil DIN 51524-535			
Fluid Temperature	°C (°F)	-20 to +80 (-5 to +175)		
Viscosity	cSt	5 to 500		
Rated Flow ⁽¹⁾	l/min	50 to 100	100 to 170	170 to 250
	(US gal/min)	(13.2 to 26.4)	(26.4 to 44.9)	(44.9 to 66.0)
Flow Maximum	l/min	95 to 189	189 to 321	321 to 475
	(US gal/min)	(25.1 to 49.9)	(49.9 to 84.8)	(84.8 to 125.5)
Leakage at 100 bar ⁽²⁾	l/min	<1 (0.4)	<2 (0.5)	<3 (0.8)
	(US gal/min)			
Filtration	ISO 4406 (1999) 18/16/13			
Static/Dynamic Data				
Response Time at 100% Step Input ⁽³⁾	ms	< 6	< 7	< 7
Frequency Response (-3dB gain, ±25% signal) ⁽³⁾	Hz	> 150	> 120	> 100
	Hz	> 150	> 120	> 100
Frequency Response (-90deg phase, ±25% signal)	Hz	> 150	> 120	> 100
Hysteresis	%	< 0.2		
Threshold	%	< 0.1		
Null Shift	%	< 1		

1) Axis cut valve, tested at 70 bar according to ISO-10770-1-8.1.4

2) Axis cut valve

3) Measured as 90% output rise time with Δ70 bar P-T (two control edges)





Performance Graphs

50lpm – 100lpm

Step Response (1)

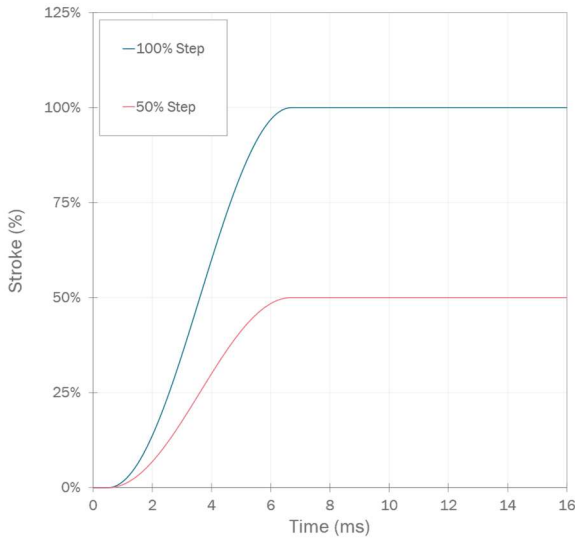

Flow vs Command

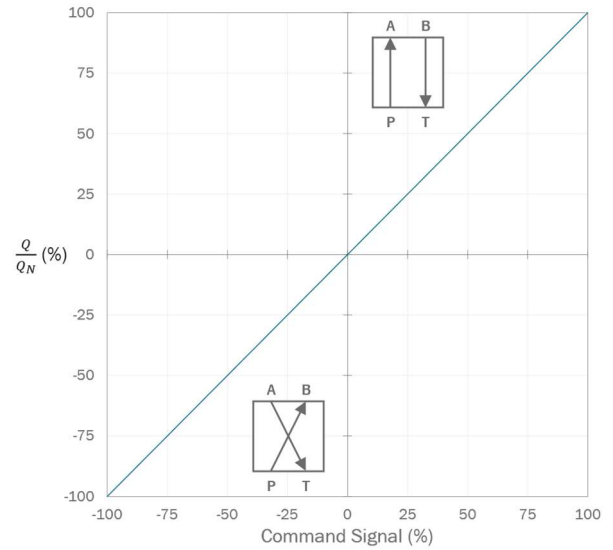

Frequency Response (1)

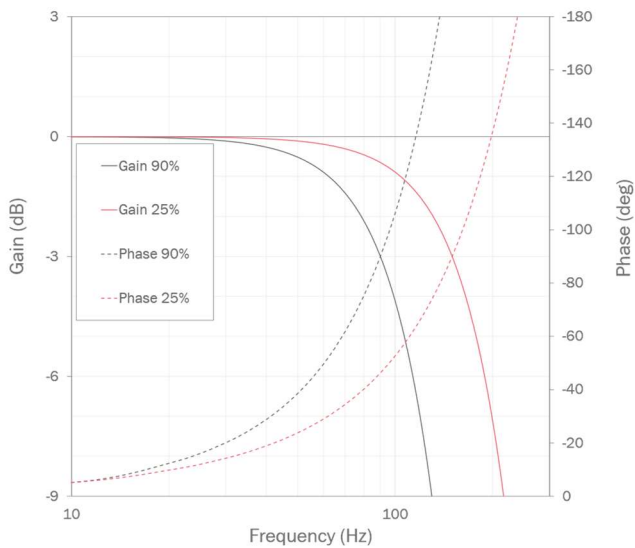

Pressure Gain

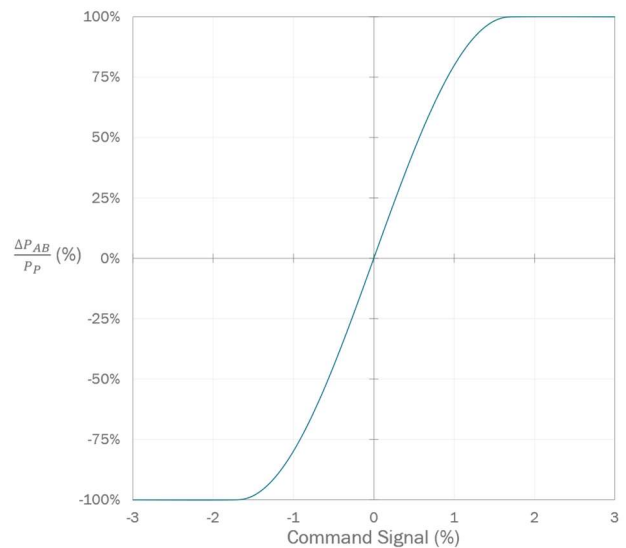

1) Measured at a 70 bar pressure drop.





100lpm – 170lpm

Step Response (1)

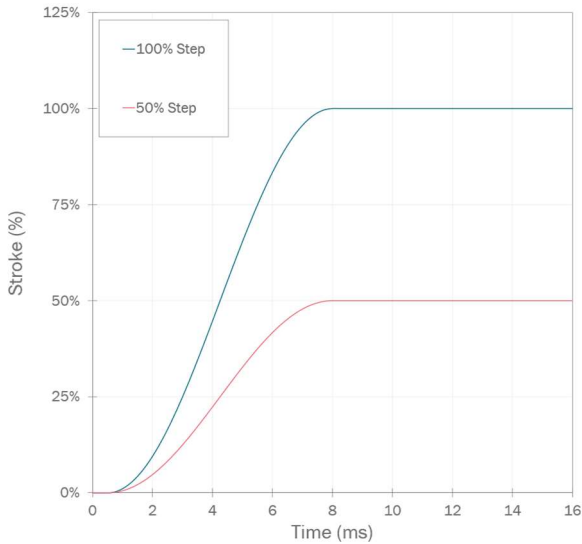

Flow vs Command

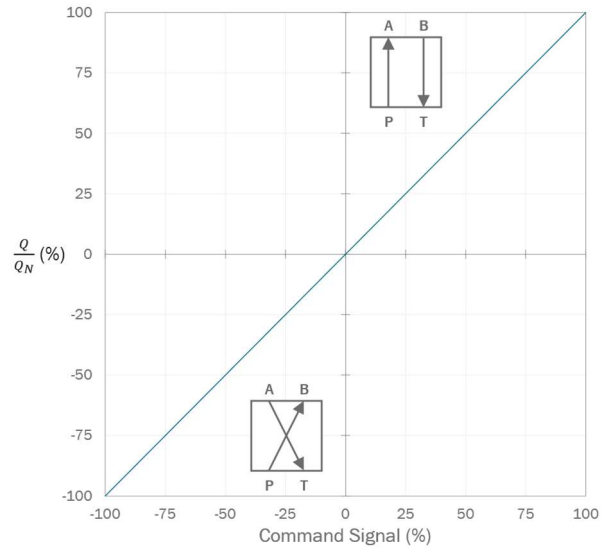

Frequency Response (1)

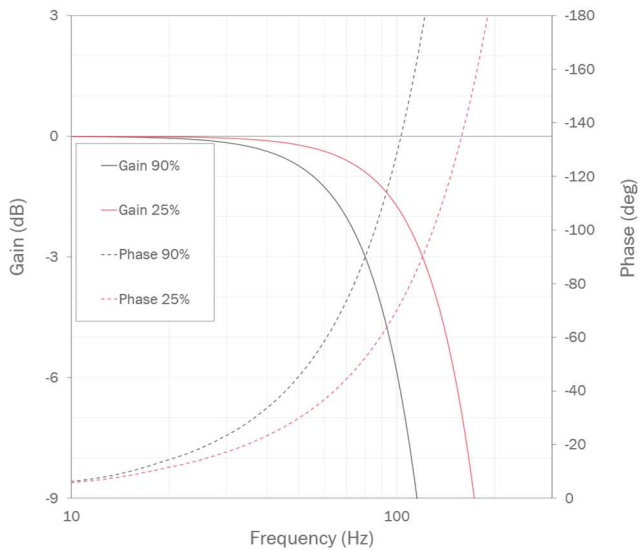

Pressure Gain

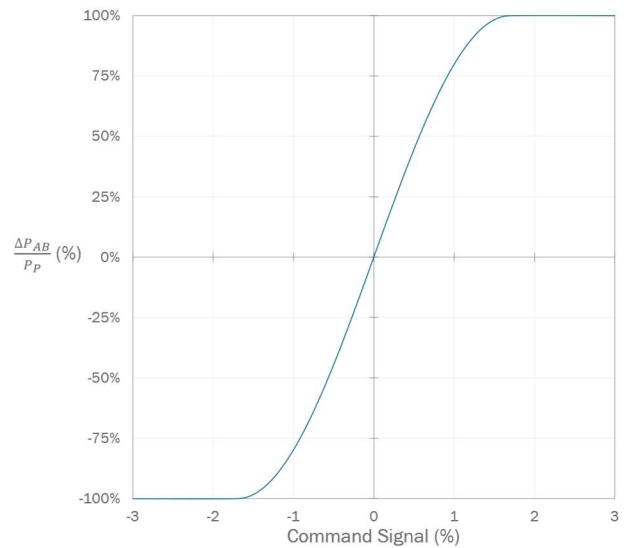

1) Measured at a 70 bar pressure drop.





170lpm – 250lpm

Step Response (1)

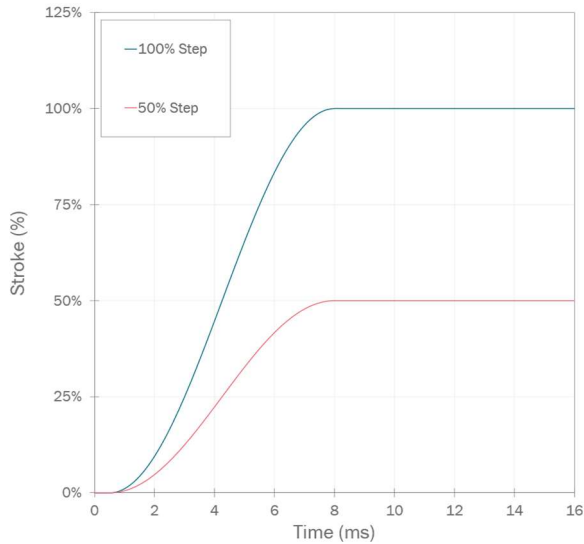

Flow vs Command

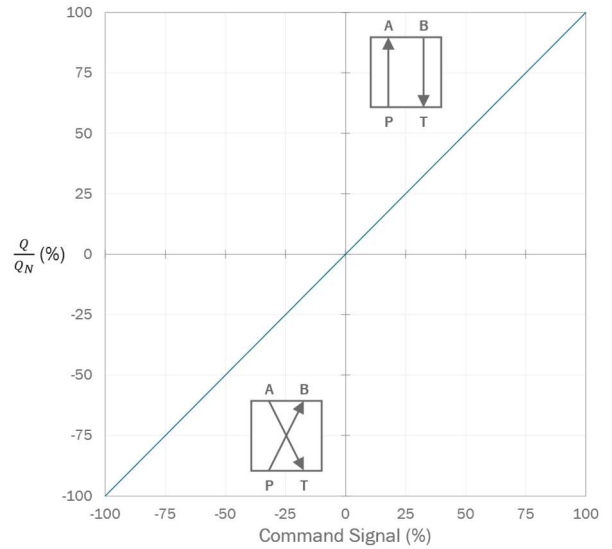

Frequency Response (1)

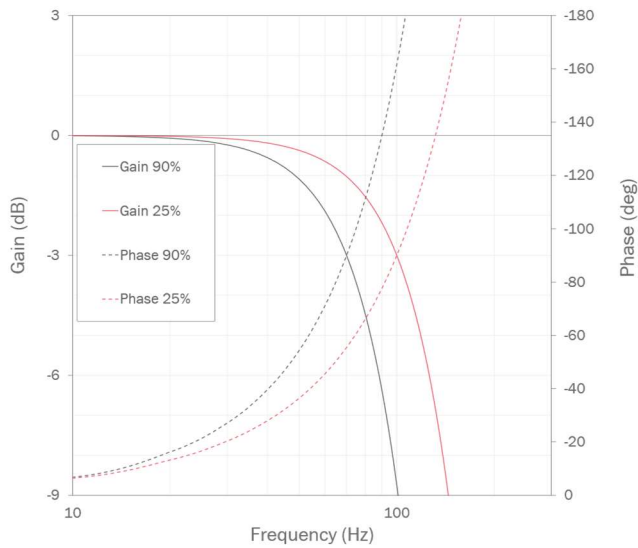

Pressure Gain

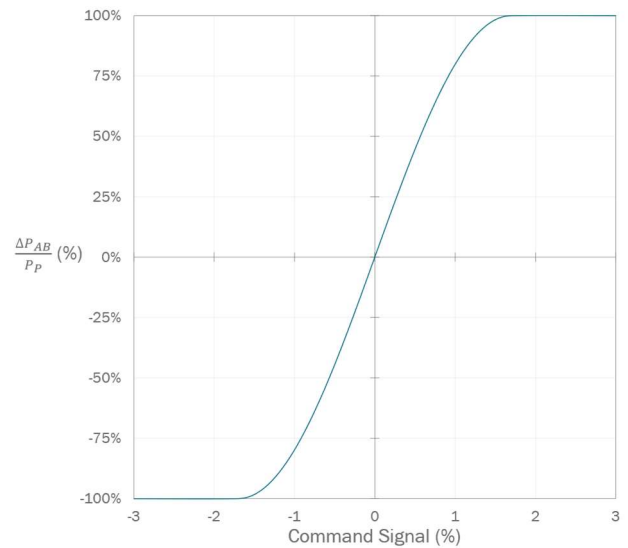

1) Measured at a 70 bar pressure drop.





Electronics Data

Ratings of the valve electronics vary based on selected command input.

±10 V

Absolute Maximum Ratings ⁽¹⁾		Min.	Typical	Max.
Supply Voltage	V	0	-	30
Differential Input Signal	V	-10.5	-	10.5
Input Signal Common Mode Offset	V	-10	-	10
Normal Operating Conditions				
Supply Voltage	V	22	24	30
Absolute maximum current draw ⁽²⁾	A	-	-	15
Quiescent Power Draw	W	-	2.5	-
Differential Input Signal	V	-10	-	10
Input Impedance	kΩ	200	-	-
Output Signal	V	-10	-	10
Output Impedance	Ω	-	47	-
Output Load Impedance	kΩ	1	-	-

±10 mA

Absolute Maximum Ratings ⁽¹⁾		Min.	Typical	Max.
Supply Voltage	V	0	-	30
Differential Input Signal	mA	-25	-	25
Input Signal Common Mode Offset	V	-10	-	10
Normal Operating Conditions				
Supply Voltage	V	22	24	30
Absolute maximum current draw ⁽²⁾	A	-	-	15
Quiescent Power Draw	W	-	2.5	-
Differential Input Signal	mA	20	-	20
Input Impedance ⁽³⁾	Ω	-	499	-
Output Signal	mA	-10	-	10
Output Load Impedance ⁽⁵⁾	Ω	-	-	650



S10 Pro Datasheet



±20 mA

Absolute Maximum Ratings ⁽¹⁾		Min.	Typical	Max.
Supply Voltage	V	0	-	30
Differential Input Signal	mA	-25	-	25
Input Signal Common Mode Offset	V	-10	-	10
Normal Operating Conditions				
Supply Voltage	V	22	24	30
Absolute maximum current draw ⁽²⁾	A	-	-	15
Quiescent Power Draw	W	-	2.5	-
Differential Input Signal	mA	20	-	20
Input Impedance ⁽³⁾	Ω	-	499	-
Output Signal	mA	-20	-	20
Output Load Impedance ⁽⁵⁾	Ω	-	-	650

+4 to +20 mA

Absolute Maximum Ratings ⁽¹⁾		Min.	Typical	Max.
Supply Voltage	V	0	-	30
Voltage Mode Differential Input Signal	mA	-25	-	25
Input Signal Common Mode Offset	V	-10	-	10
Normal Operating Conditions				
Supply Voltage	V	22	24	30
Absolute maximum current draw ⁽²⁾	A	-	-	15
Quiescent Power Draw	W	-	2.5	-
Differential Input Signal	mA	4	-	20
Differential Input Signal for drive off ⁽⁵⁾	mA	-20	-	2
Input Impedance ⁽³⁾	Ω	-	499	-
Output Signal	mA	4	-	20
Output Load Impedance ⁽⁵⁾	Ω	-	-	650



S10 Pro Datasheet



±5 V

Absolute Maximum Ratings ⁽¹⁾		Min.	Typical	Max.
Supply Voltage	V	0	-	30
Voltage Mode Differential Input Signal	V	-5.5	-	5.5
Input Signal Common Mode Offset	V	-5	-	5
Normal Operating Conditions				
Supply Voltage	V	22	24	30
Absolute maximum current draw ⁽²⁾	A	-	-	15
Quiescent Power Draw	W	-	2.5	-
Differential Input Signal	V	-5	-	5
Input Impedance	kΩ	200	-	-
Output Signal	V	-5	-	5
Output Impedance	Ω	-	47	-
Output Load Impedance	kΩ	1	-	-

- 1) Conditions outside of the absolute maximum ratings may cause permanent damage to the valve. Operation of the product outside of the nominal operating conditions is not guaranteed and may affect product reliability.
- 2) Maximum current draw occurs during chip shear events or operation at high frequencies (e.g. Close to -3dB frequency) and at maximum rated flow. Typical operating conditions require significantly less current
- 3) Current inputs use a 0.1% tolerance shunt resistor to measure demand current.
- 4) The value of the shunt resistor to measure output current should not exceed stated maximum value.
- 5) A current in this range will disable the motor drive until a current outside this range is received at the command input.

Valves with Enable Function

Valves can be provided with an enable function. This allows the valve to be enabled or disabled by varying the voltage into the enable pin (see page 9 for a pin out diagram). Note that valves with a code C command type can also be enabled or disabled using the command signal; see the corresponding table above for further details.

Normal Operating Conditions		Min.	Typical	Max.
Voltage for Drive Enable ⁽¹⁾	V	9	-	60
Voltage for Drive Disable	V	0	-	2
Input Impedance	kΩ	30	-	-

- 1) The enable pin is pulled up to Supply + within the valve via 30k. The enable pin may be left floating to enable the valve.



Electronic Interface Diagrams

6 + PE Circular Connector (Code E)

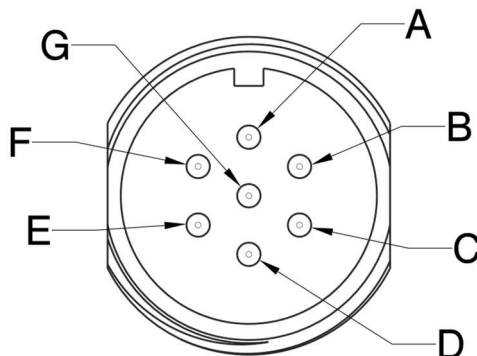

Type: Case-Mounted
Termination: Connector according to EN 175201-804/MIL 5015 equivalent, shell size 14
Number of Contacts: 7

Pin	Function	Description
A	Supply +	+24 V
B	Supply 0 V	0 V
C	Output - Enable input ⁽¹⁾	Output 0 V Reference Drive enable input ⁽¹⁾
D	Input +	Differential input signal, +
E	Input -	Differential input signal, -
F	Output +	Output signal
G	Earth	-

1) When the enable function is selected, the function of pin C is the enable input. This replaces the standard pin function.

S10 Pro Datasheet



4 Pin Circular Connector (Code E4)

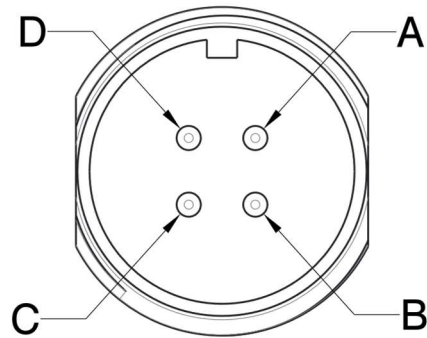

Type: Case-Mounted
Termination: Amphenol™ ACS02E14S-2P
Number of Contacts: 4

Pin	Function	Description
A	Supply +	+24 V
B	Input +	Differential input signal, +
C	Input -	Differential input signal, -
D	Supply 0 V	0 V

Standards References

EMC Regulations: EN 61000-6-2
EN55011:1998+A1
Performance Tests: ISO 10770-1
Pressure Rating: ISO 10771
Hydraulic Interface: ISO 10372-01-01-0-92





Unit Dimensions

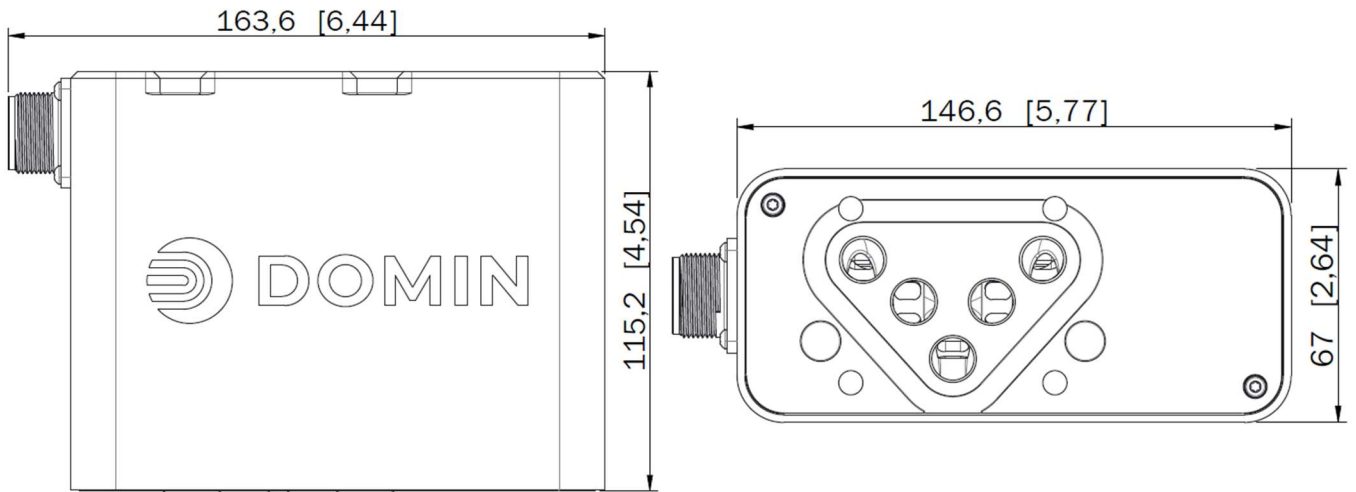

Nominal dimensions are displayed in mm. Not to scale.

Mounting Dimensions

	P	A	B	T	T1	X1 ¹	Y ¹	F1	F2	F3	F4	
Diameter Ø	mm	11.2	11.2	11.2	11.2	11.2	6.3	6.3	M6	M6	M6	M6
X Position	mm	27	16.7	37.3	3.2	50.8	-8.0	62.0	0	54	54	0
Y Position	mm	6.3	21.4	21.4	32.5	32.5	11	11	0	0	46	46

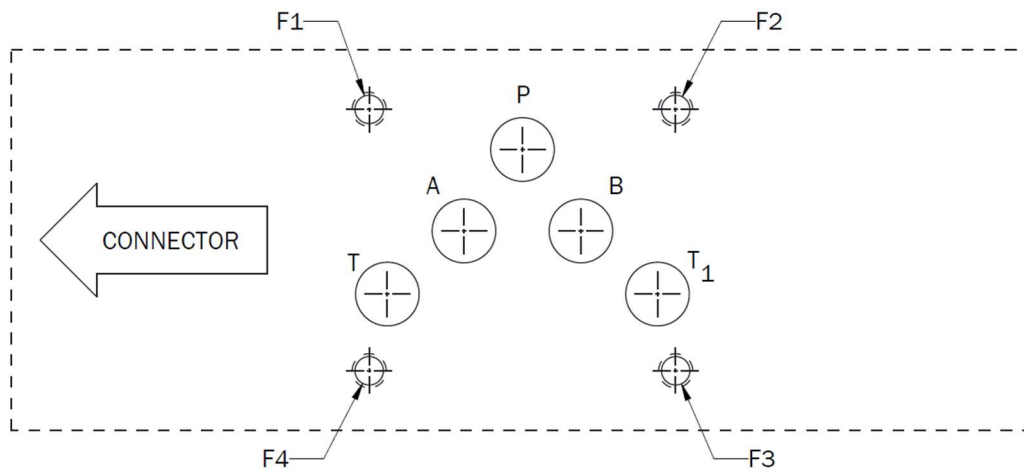

1. Valve includes seal grooves for X and Y ports for installation in existing systems – X and Y connections are NOT required for valve operation.



S10 Pro Datasheet



Bolts (F1, F2, F3, F4)

Type: M6 x 120 DIN EN ISO 4762-10.9
Required Torque: 13 Nm

O-Rings (P, A, B, T, T1, X*, Y*)

Type: 5x ISO 3601-1-014
Material: NBR, EPDM or Viton, 70 Shore A
Hardness: 70 Shore A

Type: *2x ISO 3601-1-011 (If Manifold Has X & Y Ports)
Material: NBR, EPDM or Viton, 70 Shore A
Hardness: 70 Shore A

*Port X & Y not in use, seals are for blanking only.

Variants on request

At Domin, we are proud of our ability to offer tailored solutions that meet our customers' specific needs. If you require a non-standard configuration, or a bespoke modification, we are confident we can provide you with the best solution. Talk to us using the contact details provided and one of our team will respond as soon as possible



S10 Pro Datasheet



Code 1 Rated Flow	
Any value in range 50 to 250	
Rated flow in l/min for 35 bar ΔP per control edge	
R – Suffix for reversal of A and B port e.g. 250R	

Code 2 Spool Lap Condition	
A	Axis cut (1% overlap linearised)
O	3% Overlap (linearised to 50% gain over centre)
D	10% Overlap (with flow dead band)
X	For other options please enquire

Code 3 Control Method	
A	± 10 V
B	± 20 mA
C	4 to 20 mA
D	± 5 V
X	For other options please enquire
For differing input and output signals, use two letters, e.g. AC denotes ± 10V Input and 4 to 20mA output	

Code 4 Power off Position	
C	Centre
X	For other options please enquire

Code 9 Custom ID	
Assigned individually to any with customised options upon enquiry	

Code 8 Seal Material	
N	Nitrile
V	Viton
X	For other options please enquire

Code 7 Fluid Type	
R	Recommended - any hydraulic oil in accordance with DIN 51524, filtered in accordance with ISO4406 18/16/13. Compatibility with water-free synthetic fluids available on enquiry.
X	For other options please enquire

Code 6 Enable Mode	
Y	Enable mode on ¹
N	No Enable Functionality

Code 5 Electrical Connector	
E	6 pin + PE circular connector ²
E4	4 pin circular connector ²
X	For other options please enquire

1. Only available with connector option E
 2. EN 175201-804/MIL 5015 equivalent connector, shell size 14

